

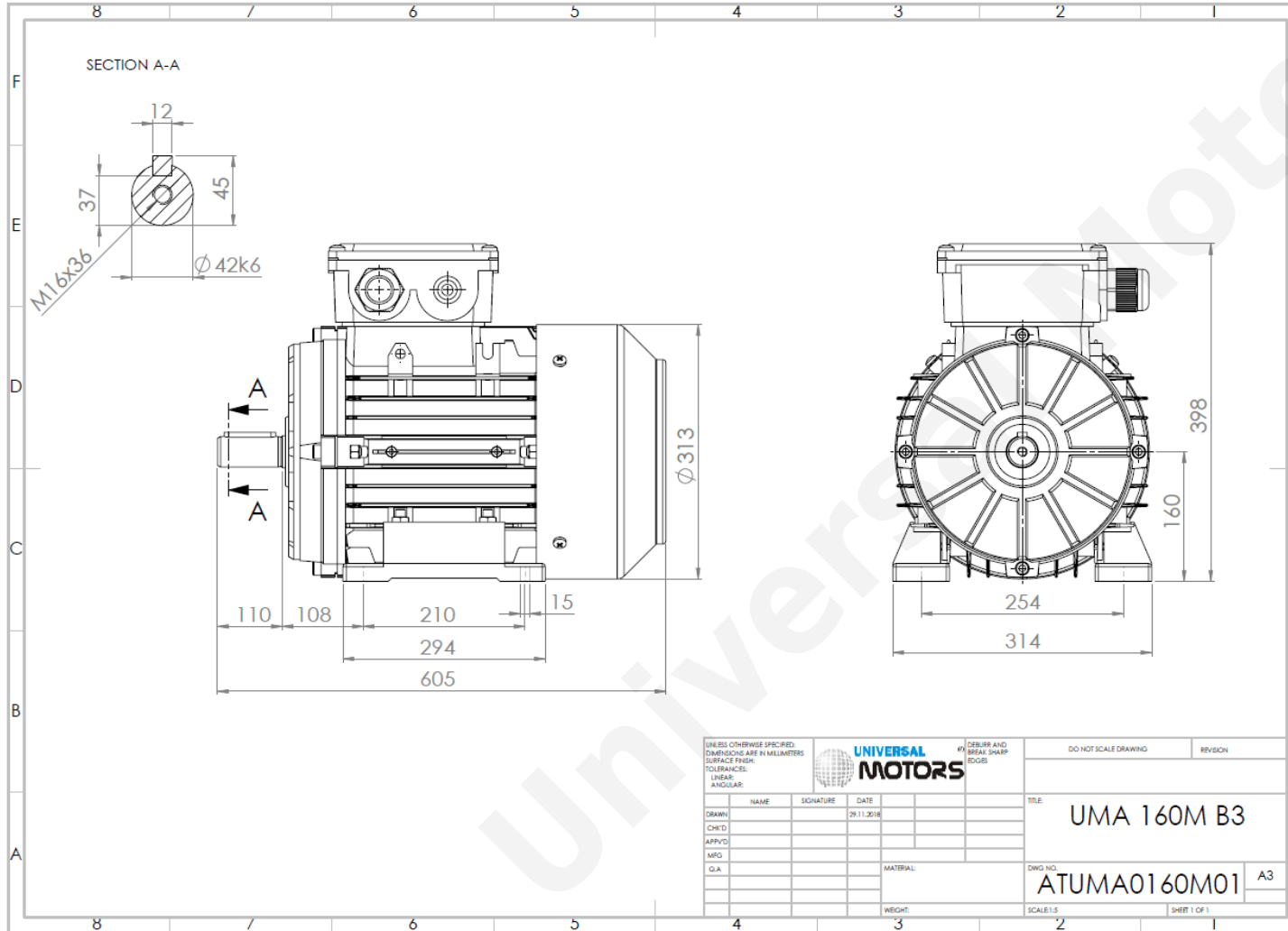

TECHNICAL DATA

Three Phase Electric Motors - Aluminum Frame
 UM2A 160M1-2
 11 kW / 15 Cv
 2950 RPM



Motor type:	UM2A 160M1-2
Output:	11 kW / 15 Cv
Speed (min ⁻¹):	2950 RPM
Frequency:	50 Hz
Voltage:	400 V
Current:	20.0 A
Power factor (Cos Ø):	0.89
Poles:	2
Insulation class:	F
Temperature rise Class:	B
Efficiency 50%:	88.2 %
Efficiency 75%:	89.5 %
Efficiency 100%:	89.4 %
Torque:	36 N.m
Tstarting/Tnominal:	2.6
Istarting/Inominal:	8.4
Tmaximum/Tnominal:	3.4
Noise:	86 Db(A)
Weight:	77 Kg
Brake AC:	AC8
Torque Brake DC:	200 N.m
Bearing DE:	6309 2Z
Bearing NDE:	6309 2Z
Torque Brake AC:	200 N.m
Brake DC:	K8

Regime - S1

Altitude - 1000m

Environment Temperature - 40°C

CONTACTS:

UNIVERSAL MOTORS Tel: +351 252 299 080
 Rua de São Brás,745 Fax: +351 252 299 089
 4480-782 VILA DO CONDE Mail: geral@universalmotors.pt

* References applied only in the UK